

SPECIFICATION / 規格表

ITEM / 項目		SET-28	SET-32	SET-36
MODEL 機種		SET-2860 SET-3260 SET-3660	SET-2880 SET-3280 SET-3680	SET-28120 SET-32120 SET-36120 SET-28160 SET-32160 SET-36160 SET-28200 SET-32200 SET-36200 SET-28240 SET-32240 SET-36240 SET-28280 SET-32280 SET-36280
CAPACITY 工作範圍				
Swing Over Bed 床面上最大旋徑		730 mm (28")	830 mm (32")	930 mm (36")
Swing Over Cross Slide 橫送台上最大旋徑		500 mm (20")	600 mm (23")	700 mm (27-1/2")
Swing in Gap 凹口上最大旋徑		1000 mm (40")	1100 mm (44")	1200 mm (47")
Width of Gap 凹口工作寬度		225 mm (8-7/8")		
Distance Between Centers 兩心間距離		1500 mm (60")	2000 mm (80")	3000 mm (120")
		4000 mm (160")	5000 mm (200")	6000 mm (240")
		7000 mm (280")		
HEAD STOCK 主軸箱				
Spindle Bore 主軸孔徑		105 mm / *153 mm (OPT)		
Spindle Nose 主軸鼻端		A2-8 / *A2-11, D1-11 (OPT)		
Taper of Center 中心針斜度(莫氏)		M.T. No. 5 / * M.T. No. 6		
Range of Spindle Speeds 主軸變速範圍		15-1000 / *10-700 RPM		
Number of Spindle Speeds 主軸變換段數		12 Changes		
FEEDS & THREADS CUTTING 進給與車牙				
Longitudinal Feeds 縱向進刀量範圍		0.05-0.7 mm/rev		
Cross Feeds 橫向進刀量範圍		0.025-0.35 mm/rev		
Inch Threads 英制螺紋(徑部螺紋)		2-28 Thread/in, (D.P. 4-56)		
Metric Threads 公制螺紋(模數螺紋)		0.8-14 mm/Thread, (M.P. 0.5-7)		
Leadscrew 導線桿直徑及螺距		Ø45 mm (1-3/4") x 2T.P.I. / * P 12 mm (OPT)		
CARRIAGE 滑座				
Cross Slide Travel 橫送台移動範圍		425 mm (16-1/2")		
Compound Rest Travel 複式刀座移動範圍		250 mm (10")		
TAILSTOCK 尾座				
Quill Diameter 心軸直徑		95 mm (3-3/4") / * 105 mm (4-1/8")		
Quill Travel 心軸行程		230 mm (9")		
Taper of Quill Center 頂心斜度		M.T. No.5 / * M.T. No.6		
BED 床體		ONE PIECE HEAVY DUTY 一體成型		
Width of Bed 床面寬度		460 mm (18-1/8")		
Length of Bed 床身長		3050 mm (120")	3550 mm (140")	4550 mm (180")
		5550 mm (219")	6550 mm (258")	7550 mm (298")
		8550 mm (338")		
Main Motor 主馬達		15HP x 4P / * 20HP x 4P (OPT)		
Weight (Approx) 重量(約)		5400 kg	5800 kg	6600 kg
		7400 kg	8200 kg	9000 kg
		9000 kg		
Packing Size (LxWxH) 裝箱尺寸(長x寬x高)		3500 x 1600 x 1900 mm	4000 x 1600 x 1900 mm	5000 x 1600 x 1900 mm
		6000 x 1600 x 1900 mm	7000 x 1600 x 1900 mm	8000 x 1600 x 1900 mm
		9000 x 1600 x 1900 mm		

*Specifications are subject to change without notice for further design improvement. *本公司備有設計變更及規格變更之權力，若有變更恕不另行通知。

STANDARD ACCESSORIES 標準附件

Back Plate 1 PC	連接板 1個
Center Sleeve 1 PC	心軸套筒 1個
Center(M.T.5#) 2 PCS	中心針 2支
Tool Post Wrench 1 PC	刀架螺絲把手 1個
Anchor Bolt 1 SET	地基螺絲 1組
Tool Box & Tool 1 SET	工具箱及調整工具 1組
Coolant Pump 1 SET	冷卻泵浦 1組
Work Light 1 PC	工作燈 1個

OPTIONAL ACCESSORIES 特別附件

3-Jaw Scroll Chuck	三爪夾頭
4-Jaw Independent Chuck	四爪夾頭
4-Jaw Face Chuck	四爪花盤
Face Plate	面盤
Taper Turning Attachment	斜度裝置
Follow Rest	跟刀架
Longitudinal Rapid Traverse Device	縱向快速移動裝置
Steady Rest	中心架
CE	CE



三鋒機器工業股份有限公司
SUN FIRM MACHINERY IND.CO.,LTD.
 台灣省台中縣大里市工業區工業11路155號
 NO. 155, 11 RD TA-LI INDUSTRIAL PARK, TAICHUNG 412, TAIWAN
 TEL: 886-4-24913781~6 FAX: 886-4-24915322
 E-mail: sunfirm@ms34.hinet.net http://www.sunfirm.com
 (48 year experience of professional lathe manufacturing)



SUN FIRM

MACHINERY

▲ 廠房建坪: 6000平方米
 FACTORY SQUARE: 6000m²



重切削強力精密車床

HEAVY DUTY PRECISION LATHE

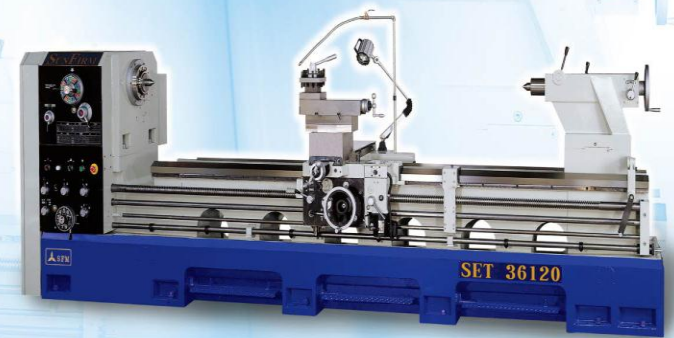

三鋒機器工業股份有限公司
SUN FIRM MACHINERY IND.CO.,LTD.

SFM 重切削強力精密車床

HEAVY DUTY PRECISION LATHE

HEADSTOCK

- All gears and mandrel are made of alloy steel with heat treat and precision ground.
- Rotating type speed changing system is easy to operate.

主軸箱

- 全部齒輪及槽輪都用合金鋼製成經淨熱處理及精密研磨。
- 旋轉式變速機構操作簡單。

SPINDLE

- Large bore spindle, supported by 3-point precision bearings.
- Suitable for heavy-duty cutting.

主軸

- 超大直徑主軸，主軸孔徑 105mm，153mm (OPT)。
- 超精密軸承三點支持式。

APRON AND SADDLE

- Easy-operated overload protects safety device.
- Central lubrication system can be operated manually or automatically.

床護與鞍座

- 調整容易的超負荷安全裝置。
- 配有潤滑油手動和自動雙重潤滑給油系統。

TAILSTOCK

- With speed reduced quill suitable for heavy duty drilling, hand wheel is with dual dial.

尾座

- 為強壓力鑽孔作業操作之減速裝置 (1/4) 公制、英制刻度心軸。

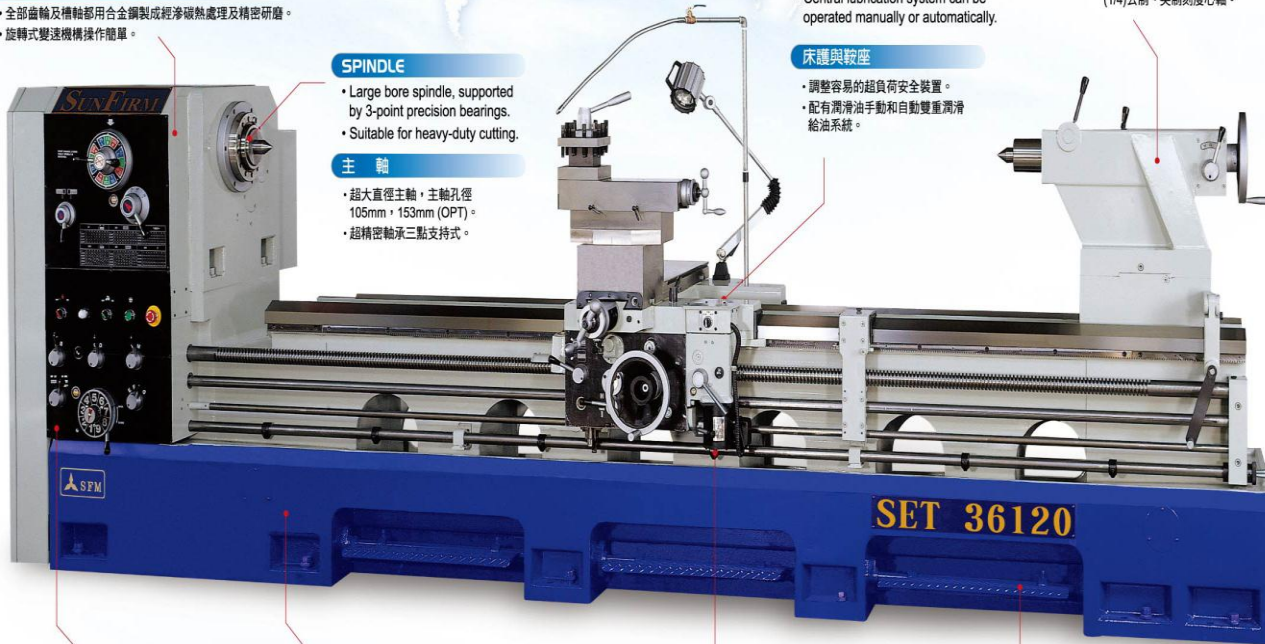

GEAR BOX

- Universal gear box design, is able to cut metric thread, Imperial thread, module thread without changing gears.

齒輪箱

- 全能車製螺紋機構，任意車製。
- 公制螺紋、英制螺紋、模數螺紋、徑節螺紋，不須變換齒輪。

LATHE BED

- High tensile ribs structure, high precision and wide bed surface.
- With hardened and precision ground.
- One piece structure lathe bed enhances the machine life and working performance.

床身

- 高剛性之肋骨結構。
- 高精度寬大床面、經淬火並研磨。
- 一體成型落地底座適合重型工件並延長使用年限。

AUTO LONGITUDINAL STOP

- Auto longitudinal travel device will control the feed of tool post.

自動停止裝置

- 自動縱進刀的進刀距離自動停止控制可調整任意進刀距離。

EMERGENCY BRAKE SYSTEM

- More safe emergency brake system can shut off power supply simultaneously.

緊急煞車

- 腳制車裝置，能直接切斷電源，操作迅速確實。



● 強力尾座
Heavy Duty Tailstock

● 面盤
Face Plate

● 中心架
Steady Rest

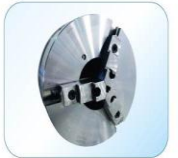

● 三爪強力夾頭
3-Jaw Scroll Chuck



● 斜度裝置
Taper Turning Attachment



● 跟刀架
Follow Rest



● 美式四爪夾頭
4-Jaw Independent Chuck



● 四方向快送裝置
4 Way Rapid Traverse Device

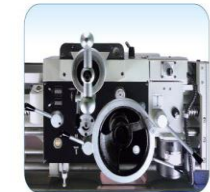

● 縱向快送裝置
Longitudinal Rapid Traverse Device



● 英式四爪夾頭
4-Jaw Face Chuck