

SPECIFICATION / 規格表

ITEM / 項目		SDT-32	SDT-36	SDT-40	SDT-44	SDT-48
MODEL	機 種	SDT-3260 SDT-3660 SDT-4060 SDT-4460 SDT-4860	SDT-3280 SDT-3680 SDT-4080 SDT-4480 SDT-4880	SDT-32120 SDT-36120 SDT-40120 SDT-44120 SDT-48120	SDT-32160 SDT-36160 SDT-40160 SDT-44160 SDT-48160	SDT-32200 SDT-36200 SDT-40200 SDT-44200 SDT-48200
CAPACITY 工作範圍						
Swing Over Bed	床面上最大旋徑	830 mm (32")	930 mm (36")	1030 mm (40")	1130 mm (44")	1230 mm (48")
Swing Over Cross Slide	橫送台上最大旋徑	580 mm (22.8")	680 mm (26.8")	780 mm (30.7")	880 mm (34.7")	980 mm (38.6")
Swing in Gap	凹口上最大旋徑	1100 mm (43")	1200 mm (47")	1300 mm (51")	1400 mm (55")	1500 mm (59")
Width of Gap	凹口工作寬度	250 mm (10")				
Distance Between Centers	兩心間距離	1500 mm (60")	2000 mm (80")	3000 mm (120")	4000 mm (160")	5000 mm (200")
HEAD STOCK 主軸箱						
Spindle Bore	主軸孔徑	105 mm / * 153 mm, 230 mm (OPT)				
Spindle Nose	主軸鼻端	A2-8 / * A2-11, D1-11, A2-15 (OPT)				
Taper of Center	中心針斜度(莫氏)	M.T. No. 5 / * M.T. No. 6				
Range of Spindle Speeds	主軸變速範圍	15~1000 / *10~700 RPM				
Number of Spindle Speeds	主軸變換段數	12 Changes				
FEEDS & THREADS CUTTING 進給與車牙						
Longitudinal Feeds	縱向進刀量範圍	0.05~0.7 mm/rev				
Cross Feeds	橫向進刀量範圍	0.025~0.35 mm/rev				
Inch Threads	英制螺紋(徑部螺紋)	2-28 Thread/in. (D.P. 4-56)				
Metric Threads	公制螺紋(模數螺紋)	0.8~14 mm / Thread. (M.P. 0.5-7)				
Leadscrew	導螺桿直徑及螺距	Ø45 mm (1-3/4") x 2 T.P.I. / * P 12 mm (OPT)				
CARRIAGE 滑座						
Cross Slide Travel	橫送台移動範圍	585 mm (23")				
Compound Rest Travel	複式刀座移動範圍	250 mm (10")				
TAILSTOCK 尾座						
Quill Diameter	心軸直徑	105 mm (4-1/8") / * 125 mm (4-7/8")				
Quill Travel	心軸行程	230 mm (9")				
Taper of Quill Center	頂心斜度	M.T. No.6				
BED 床體		ONE PIECE HEAVY DUTY 一體成型				
Width of Bed	床面寬度	510 mm (20")				
Main Motor	主馬達	20 HP x 4P / * 25 HP x 4P				
Weight (Approx)	重量(約)	6000 kg	6500 kg	7200 kg	8000 kg	9100 kg
Packing Size (L x W x H)	裝箱尺寸 (長 x 寬 x 高)	3500 x 1800 x 2100 mm	4000 x 1800 x 2100 mm	5000 x 1800 x 2100 mm	6000 x 1800 x 2100 mm	7000 x 1800 x 2100 mm

* Specifications are subject to change without notice for further design improvement. * 本公司擁有設計變更及規格變更之權力，若有變更恕不另行通知。

STANDARD ACCESSORIES 標準附件		OPTIONAL ACCESSORIES 特別附件	
Back Plate	1 PC 連接板	1 個	3-Jaw Scroll Chuck 三爪夾頭
Center Sleeve	1 PC 心軸套筒	1 個	4-Jaw Independent Chuck 四爪夾頭
Center(M.T.6#)	2 PCS 中心針	2 支	4-Jaw Face Chuck 四爪花盤
Tool Post Wrench	1 PC 刀架螺絲把手	1 個	Face Plate 面盤
Anchor Bolt	1 SET 地盤螺絲	1 組	Taper Turning Attachment 斜度裝置
Tool Box & Tool	1 SET 工具箱及調整工具	1 組	Follow Rest 跟刀架
Coolant Pump	1 SET 冷卻泵浦	1 組	Longitudinal Rapid Traverse Device 縱向快速移動裝置
Work Light	1 PC 工作燈	1 個	Steady Rest 中心架
			CE



www.sunfirm.com

Sun Firm Machinery



三鋒機器工業股份有限公司
SUN FIRM MACHINERY IND.CO.,LTD.
 台中市大里區工業11路155號
 NO. 155, 11 RD TA-LI INDUSTRIAL PARK, TAICHUNG 412, TAIWAN
 TEL: 886-4-24913781 FAX: 886-4-24915322
 E-mail: sunfirm@ms34.hinet.net http://www.sunfirm.com



重切削強力精密車床
Heavy Duty Precision Lathe



SUN FIRM 重切削強力精密車床 Heavy Duty Precision Lathe

HEADSTOCK

- All gears and mandrel are made of alloy steel with heat treatment and precision ground.
- Rotating type speed changing system is easy to operate.

主軸箱

- 全部齒輪及標軸都用合金鋼製成經滲碳熱處理及精密研磨。
- 旋轉式變速機構操作簡單。

SPINDLE

- Large bore spindle, supported by 3-point precision bearings.
- Suitable for heavy-duty cutting.

主軸

- 超大直徑主軸，主軸孔徑 105 mm、153 mm、230 mm (OPT)。
- 超精密軸承三點支持式。

APRON AND SADDLE

- Easy-operated overload protects safety device.
- Central lubrication system can be operated manually or automatically.

床護與鞍座

- 調整容易的超負荷安全裝置。
- 配有潤滑油手動和自動雙重潤滑給油系統。

TAILSTOCK

- With speed reduced quill suitable for heavy duty drilling, hand wheel is with dual dial.

尾座

- 為強壓力鑽孔作業操作之減速裝置 (1/4) 公制、英制刻度心軸。

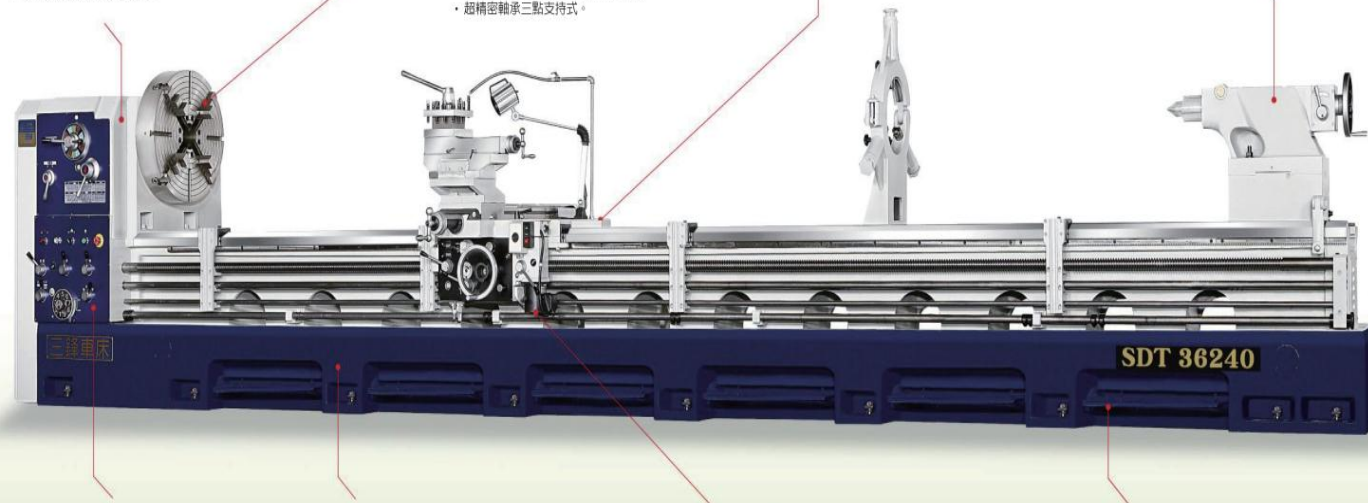

GEAR BOX

- Universal gear box design, is able to cut metric thread, Imperial thread, module thread without changing gears.

齒輪箱

- 全能車製螺紋機構，任意車製。
- 公制螺紋、英制螺紋、模數螺紋、徑節螺紋，不須變換齒輪。

LATHE BED

- High tensile ribs structure, high precision and wide bed surface.
- With hardened and precision ground.
- One piece structure lathe bed enhances the machine life and working performance.

床身

- 高剛性之肋骨結構。
- 高精度寬大床面、經淬火並研磨。
- 一體成型落地底座適合重型工件並延長使用年限。

AUTO LONGITUDINAL STOP

- Auto longitudinal travel device will control the feed of tool post.

自動停止裝置

- 自動縱進刀的進刀距離自動停止控制可調整任意進刀距離。

EMERGENCY BRAKE SYSTEM

- More safe emergency brake system can shut off power supply simultaneously.

緊急煞車

- 腳制車裝置，能直接切斷電源，操作迅速確實。



● 中心架 Steady Rest



● 強力尾座 Heavy Duty Tailstock



● 面盤 Face Plate



● 三爪強力夾頭 3-Jaw Scroll Chuck



● 美式四爪夾頭 4-Jaw Independent Chuck



● 英式四爪夾頭 4-Jaw Face Chuck



● 斜度裝置 Taper Turning Attachment



● 跟刀架 Follow Rest



● 四方向快速裝置 4 Way Rapid Traverse Device

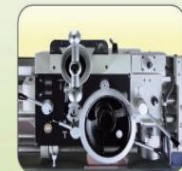

● 縱向快速裝置 Longitudinal Rapid Traverse Device